

8-2-2019

USING OPTOELECTRONIC NONCONTACT VOLTAGE RELAY IN ELECTRICAL SUPPLY SYSTEMS

R.Ch. Karimov
Tashkent State Technical University

Follow this and additional works at: <https://btstu.researchcommons.org/journal>



Part of the [Engineering Commons](#)

Recommended Citation

Karimov, R.Ch. (2019) "USING OPTOELECTRONIC NONCONTACT VOLTAGE RELAY IN ELECTRICAL SUPPLY SYSTEMS," *Technical science and innovation*: Vol. 2019: Iss. 2, Article 8.

DOI: <https://doi.org/10.51346/tstu-01.19.2.-77-0028>

Available at: <https://btstu.researchcommons.org/journal/vol2019/iss2/8>

This Article is brought to you for free and open access by Technical Science and Innovation. It has been accepted for inclusion in Technical science and innovation by an authorized editor of Technical Science and Innovation.

USING OPTOELECTRONIC NONCONTACT VOLTAGE RELAY IN ELECTRICAL SUPPLY SYSTEMS**R.Ch.Karimov***Tashkent State Technical University***Abstract**

In the article based on the results of the analysis of the existing opto-thyristor resistive circuits, a new scheme of the optoelectronic contactless voltage relay has been developed and its application in the power supply system has been considered. The possibility of controlling the operating modes of various installations amplifying electrical signals using optothyristors is presented and the ways of their inclusion in electrical circuits are presented. The optoelectronic contactless voltage relays were tested in laboratory conditions to obtain an input-output characteristic and a form of capacitance voltage. Based on the improvement of the proposed circuit, a circuit of an optoelectronic contactless voltage relay is developed and provide a high degree of reliability. The simulation of the proposed voltage relay circuits is performed using the MATLAB R2014a program, the results of which show that changes in the shape of the output voltage curve are close to a sinusoid and coincide with the results obtained analytically. As a result the obtained conditions of use make it possible to obtain a voltage with a sinusoidal shape on the load and achieve a relay return coefficient close to unity.

Key words: *thyristor, optoelectron, optothyristor, capacitor, resistor, diode, diode bridge, resistive circuit, voltage, input-output characteristic, boost booster transformer, MATLAB R2014a program, return coefficient.*

Creation of reliable and safe start-up, protection, adjustment and switching power units, which is an element of electrical equipment for alternating current circuits, is crucial for ensuring uninterrupted, accurate and fast operation of power plants [1, 9-10, 12-13, 15]. The wide range of contact devices and apparatus used for these purposes have the following disadvantages [2-5, 14, 17]:

- the appearance of an arc in contacts during the switching process and the need for a suitable size chamber to extinguish it;
- insufficient resistance to electrical and mechanical absorption of contacts;
- the presence of large inertia in the system during the switch-off;
- erosion and erosion from contact current;
- limited service time and relatively low reliability;
- the amount of power consumed in the control chains;
- the cost of operating services;
- voltage at connection;
- not all simultaneous interconnection;
- presence of noise etc.

The development of semiconductor element techniques and the industrial production of optotransistors, the clear switching of new electrical equipment on the basis of optoparks and the creation of precision devices for the manufacture [1, 4, 6-8, 11, 18].

The development of an optical-electronic contactless relay scheme for various currents

and voltages has enabled the creation of optical-electronic non-contact switching devices and tuners for use in the power supply system.

Currently, the use of optical-electronic non-contact voltage relays in the power supply system has opened new possibilities in the power supply system, while improving the quality of electricity and reducing costs. The use of optical-electronic contactless relays in the power supply system provides the following benefits [1, 3-5, 10, 12-13, 15, 18]:

- contactless and reliable management of electricity consumers in industrial and industrial enterprises;

- control systems in the power supply system and quality control of electricity;
- management of emergency and subsequent modes of power supply system;
- high service life and reliability;
- the ability to adjust the output parameters according to the given legislation;
- ability to reduce overload during load switching;
- ability to operate even in the most difficult weather conditions;
- simplicity of explosive designs, etc.

Optical-electronic non-contact voltage relay systems are used for the following purposes [1, 3-5, 9, 12-18]:

1. *For switching and controlling currents in alternating currents of low and high voltage.*

In the natural switching of the thyristors, non-contact switching devices will disconnect the short circuit currents in the 50 Hz power line for 0.01 seconds. For forced thyristor switching this time can be reduced to 0.002 seconds. The selectivity (selectivity) of the protection can be quickly realized by using an optical-electronic contactless voltage relay. In addition, the optical-electronic contactless voltage relay allows the circuit to be switched on endless times without the arc and over voltage;

2. *Operation of alternating current furnaces.* With the help of an optical-electronic contactless voltage relay, it is possible to cut off the stoves and protect them from short-circuit currents and symmetries;

3. *Automatic disconnection by alternating current in contact, point and weld.* It can also be used in place of the contactors for electrical welding equipment;

4. *Limiting the actual value of the phase voltage through an optical-electronic contactless voltage relay.* At the same time, the service life of electric lamps and other active energy consumers can be extended;

6. *Adjustment of reactive capacitors.* This allows the coefficient to remain flat or compensate for reactive power at the required intervals;

7. *Limitation of salt operation in welding transformers.* This will allow you to disconnect the transformer in the absence of an electric arc and connect it immediately when the contact between the electrode and the welding form is in contact;

8. *Replacement of power transformer shaft section.* This restricts the current from the reactor and resistors, which is achieved by changing the voltage switch voltage when the load current passes through zero.

Important technical advantages of transformer and electromagnetic relays (control chain and galvanic load solution) also apply to these optotistors. At the same time, optotyristors are significantly superior to electromagnetic relays with reliable, safe, resistant, transient and frequency characteristics [1, 3-4].

The development of an optical-electronic contactless voltage relay based on optoparas provides a sinecode of the voltage curve at load and improves weight and volume parameters in modern electrical devices [1, 3-4, 12, 14-15, 17-18].

Simplicity of optical-electronic contactless voltage control and optotirist characteristics have provided them with a wide range of applications. The energy loss in semiconductor controls is much smaller than the contact equipment, and also has a high reliability as well as the small-weight parameters. Optotyristors operate at low temperatures (up to -60°C) and high temperatures (over 100°C). In most cases, the efficiency of the equipment is about 99%. The power needed to operate the optics is 100,000 times less than their current load. It does not have a moving part or a vacuum. During its operation, almost no maintenance is required. Since the currents range from mA to one thousand amperes, voltage range up to 10 kV and the action effect up to micros, the optotirist equipment has been shown to be uneven in many areas of technique [1, 3-4, 12, 14-15].

A simplified circuit of optical-electronic contactless voltage relay, which is in the sine of the voltage curve in the electrical load (Figure 1).

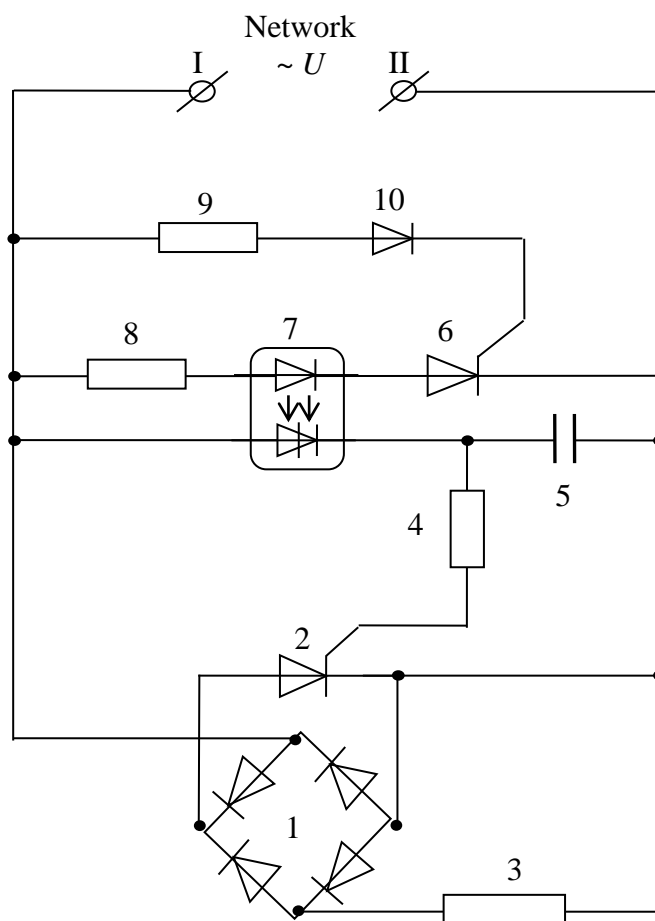

Fig.1. Principle diagram of an optical-electronic contactless voltage relay

The optical-electronic contactless relay is supplied with three resistors (diodes), diodes, thyristors, capacitors, and optotyristors, with consecutive load (3) to its supply source with the diode bridge (1) and the first thyristor (2) to its diagonal is connected. Relay comes with capacitor (5), thyristor (6), three resistors (4,8,9), optotyristors (7) and diode (10). The control electrode of the first thyristor (2) is connected to the capacitor (5) through the first resistor (4) and the cathode of the optotyristor (7). The second connector of the capacitor (5) is connected to

the cathode of the first thyristor (2), the cathode of the second thyristor (6), and the second clamp of the supply source. The second thyristor (6) is connected to the anode opticalist (7) with the diode cathode, and the anode in turn with the output of the second resistor (8). The second output of resistor (8) is connected to the optistrist (7) thyristor anode and the third resistor (9) to the output and supply source. The second output of the third resistor (9) is connected to the diode (10) and the cathode of the diode (10) is connected to the control electrode of the second thyristor (6) [4, 15, 18].

Optical-electronic contactless voltage relay works as follows:

When the input voltage of the relay reaches a certain value, the opening signal on the control electrode is sufficient to open the thyristor (6) at 90° angles and connects the opticalist (7) to the network via resistor (8). This leads to the current flowing from the diode of the optotrist (7), thereby opening the thyristor part of the optotrist (7) and connecting the capacitor (5) to the mains. The control electrode of the thististor (2) is always open as it is transmitted from the capacitor (5) through the resistor (4) to the sinusoidal voltage from the load (3). The start time of the thermostat (6) is adjusted by selecting resistor (9) [3-4, 14, 18].

Figure 2 shows the "input-output" voltage of the optical-electronic contactless relay and the voltage curve in the capacitance. The optical-electronic contactless voltage relay scheme allows for convergence of the voltage curve at the load by taking the sinusoidal shape and converging the coefficient [3-4, 6, 10, 18].

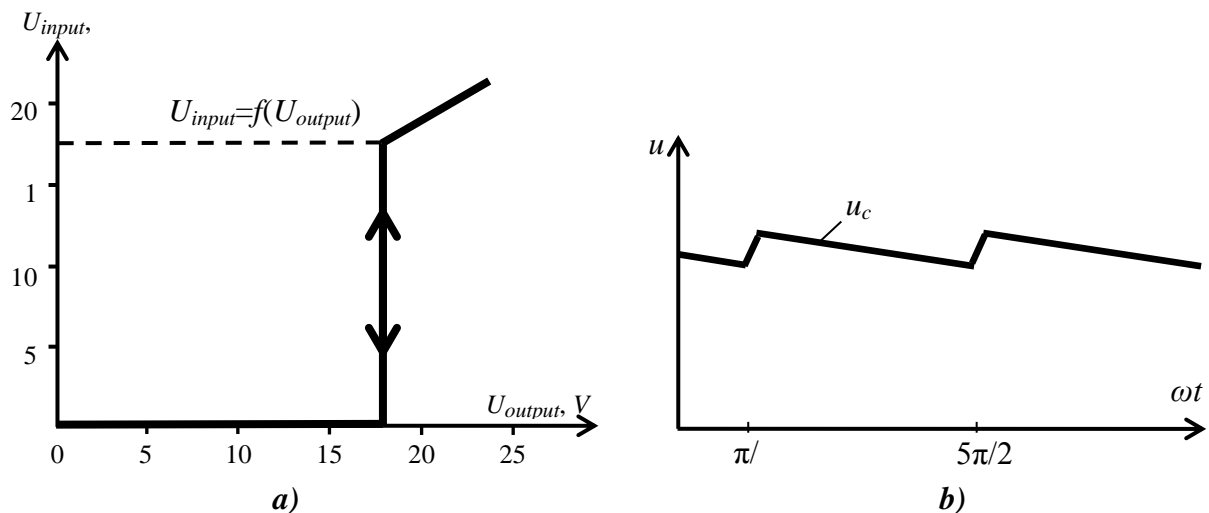

Fig.2. Optical-electronic contactless voltage relay: *a* – the "input-output" characteristic of the voltage; *b* - voltage curve of the capacitance

Modern Computer Mathematics offers a collection of Mathcad, Mathematica and other software systems for automating mathematical computing. MATLAB features high capacity [20].

MATLAB is a time-tested mathematical computational automation system based on the use of matrix operations. Matrixes are the basis for the creation and solution of broad, state equations in complex mathematical calculations, including linear algebra problems and modeling of dynamic systems and objects. An example of this is the MATLAB extension Simulink block. The Simulink block allows you to simulate real systems and devices by modeling them from functional blocks. Simulink has a large library of blocks that can be expanded and expanded by users. Bloc parameters can be entered and modified using simple tools [20].

From the results of the modeling and analysis, we can see that it is desirable to run the modeling processes through the Simulink Library Browser and SimPowerSystems blocks of MATLAB R2014a software. This is because the possibilities for more precise visualization of data and more data are analyzed [20].

The linear differential equation for the mode analysis of the diode-chain circuit, which is part of the contactless voltage relay in the form of a sinusoidal load curve, was studied by numerical methods using computer technology to determine the time to set the voltage depending on the value of the diode-capacitance chain parameters [3, 12, 19].

The proposed optical-electronic contactless relay output voltages and voltage values at different voltages are obtained on the basis of a vertical-mode test of the operating mode with the convergence coefficient and significant nominal coupling coefficient in the non-contact voltage relay scheme determined. In the circuit of optical-electronic non-contact voltage relay, which is in the sine of the voltage curve in the load the thyristor opening is provided when the load current passes through zero [2-4, 7-8, 19].

The model of the optical-electronic contactless relay circuit shown in Figure 1 is modeled by the MATLAB R2014a software Simulink Library Browser and SimPowerSystems and its performance analysis and results are shown in Figure 3.

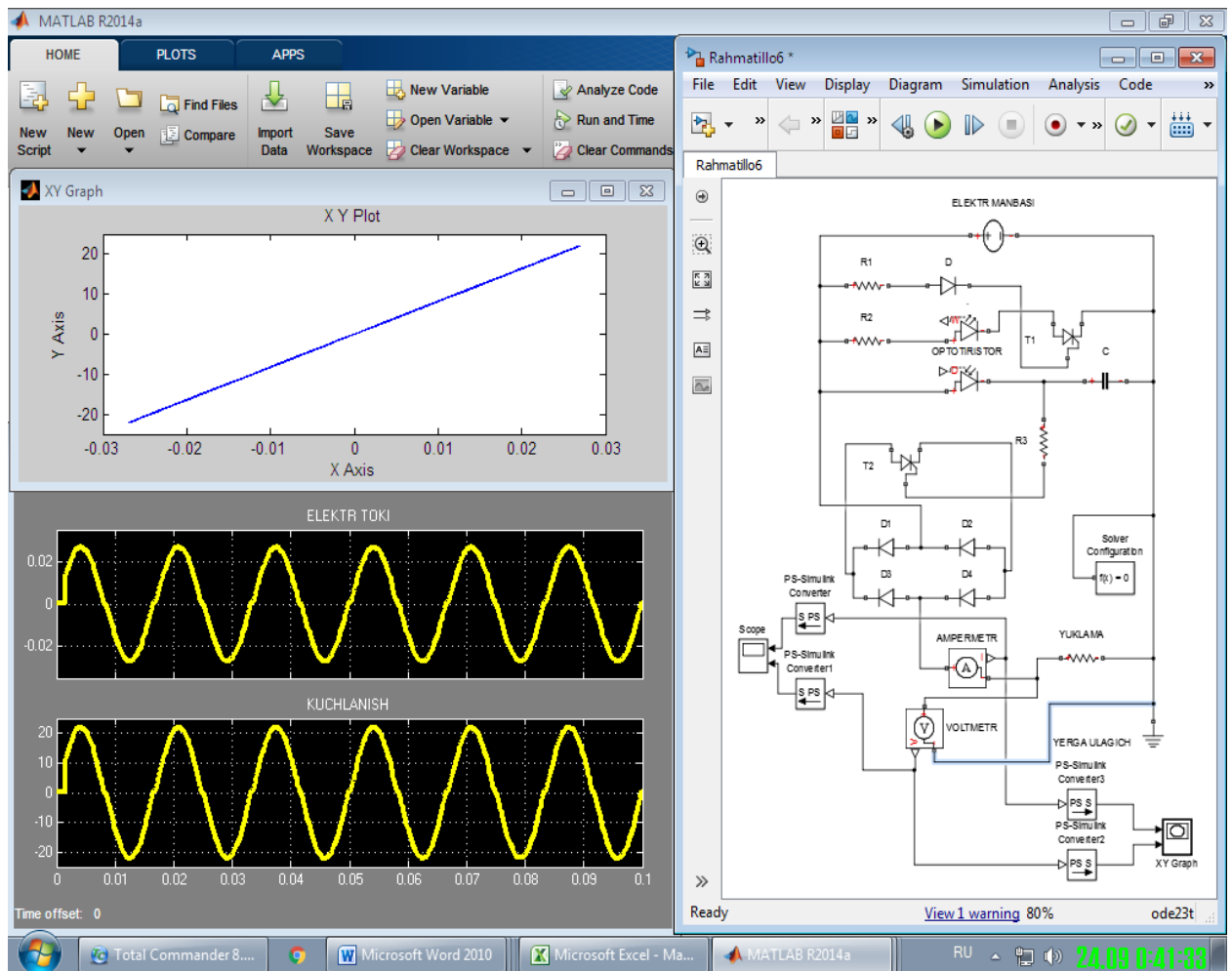

Fig.3. Modeling optical-electronic contactless voltage relay

There is great potential for the use of optical-electronic non-contact voltage relays in automatic control of industrial power supply (metallurgy, chemistry, oil, textile, etc.) and railway power supply systems.

The appearance of the optical-electronic contactless voltage relay is shown in Figure 4.

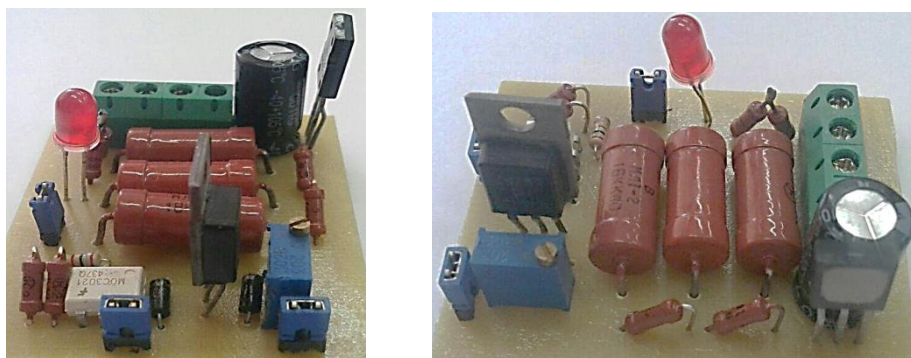

Fig.4. Optical-electronic contactless voltage exterior

This optical-electronic non-contact voltage relay was tested on the base of the "Power Supply" department of the Energy Faculty of the Tashkent State Technical University. At (2,6) *KY202II* as thyristors; *KY201II*, (10) *Д226Б* as a diode, (3,4,8,9) Resistors 820 kOm, 15 kOm, 3,8 kOm, 16 kOm as active resistors, (5) capacitor 1 kmF, (1) *КЦ402Е* as a diode bridge, *АОУ103В* as optotist, and 100 volts (3) connects to the network and the voltage curve in the load is in the sine [4, 14].

Also, the results of the studies comparing the performance of electric mechanical and non-contact voltage relays are shown in Table 1 [4, 9, 14, 16].

Table 1.

№	Indicators of use	Electric mechanical relays	Non-contact voltage relay
1.	Denial in use	-	100000 hours
2.	Number of cycles in transformations	$10^4 \div 10^6$ times	Over 10^{10}
3.	Shelf life	10÷15 year	25 year
4.	Temperature range	-60°S to $+85^{\circ}\text{S}$	-60°S to $+125^{\circ}\text{S}$
5.	Normalize contact resistance	During delivery	While not denying
6.	Stability to mechanical barriers	Availability of vibrations when switching contacts	Lack of vibrations when switching contacts
		There is a burn of contacts	No burns in contacts
		There is a false start	There is no false start
7.	Acoustic features	The presence of noise at the cut	No noise
8.	Compatibility with logical signals on input	The need to adjust the input signal	Suitable transistor transistor and complete oxidized metal oxide semiconductor
		The need to adjust with the voltage of the source	
9.	Stability to mechanical loads (linear acceleration)), g (ms^2)	15÷150	500
10.	Insulation properties	Up to 500 V	500÷3000 V
11.	Integration in assembly in production	Special mounting	Performed in the standard case
		Махсус қотириш	
12.	Control power, mW	Up to 200	5÷15

Summary. In the laboratory conditions the operating mode of the proposed optical-electronic contactless voltage circuit with constant and variable current currents was studied in experimental conditions and studied the main characteristic of the load curve in the sinusoidal

form. As a result, the convergence coefficient and significant nominal switching power in the proposed optotristor non-contact voltage relay scheme are achieved.

References

1. Karix E.D. Optoelektronika // Elektronniy konspekt lektsiy. – Minsk: BGU. 2002. S.107. <http://www.fineprint.com>
2. Usmonov E.G., Abduraimov E.X., Karimov R.Ch. Nelineynaya dinamicheskaya sep s tiristorom // Jurnal «Problemi informatiki i energetiki». Tashkent, 2006. - № 2-3. – S.37-41.
3. Usmonov E.G., Abduraimov E.X., Karimov R.Ch. Ispol'zovanie beskontaktnix rele dlya uluchsheniya kachestva elektroenergii // Vestnik TashGTU. 2012. №3-4. S.48-51.
4. Usmonov E.G., Abduraimov E.X., Karimov R.Ch. Optoelektronnoe beskontaktnoe rele napryajeniya // Патент на изобретение № IAP05122. 29.10.2015.
5. Karimov R.Ch. Research of the stabilizer of current taking into account the highest harmonicas in systems of power supply // «European Science Review» scientific journal. Austria (Vienna). 2015. №9-10. P.144-146.
6. Rasulov A.N., Karimov R.Ch. The Contactless Thyristor Device for Inclusion and Shutdown of Condenser Installations in System of Power Supply // «Eastern European» scientific journal. Dusseldorf (Germany). 2015. №4. P.179-183.
7. Karimov R.Ch. Issledovanie nelineynaya dinamicheskaya sepi s tiristornie elementov v sisteme elektrosnabjeniya // Sbornik materialov IV-mejdunarodnoy nauchnoy konferentsii "Sovremennye tendentsii texnicheskiy nauk". Rossiya, Kazan, 2015. – S.30-33.
8. Karimov R.Ch. Issledovanie nelineynaya dinamicheskaya sepi s diodnie elementov v sisteme elektrosnabjeniya // Sbornik materialov IV-mejdunarodnoy nauchnoy konferentsii "Sovremennye tendentsii texnicheskiy nauk". Rossiya, Kazan, 2015. – S.33-35.
9. Rasulov A.N., Karimov R.Ch. The Contactless Relay of Tension in System of Power Supply // «Eastern European» scientific journal. Dusseldorf (Germany). 2015. - №4. Ausgabe. – PP.174-178.
10. Rasulov A.N., Karimov R.Ch. The Contactless Thyristor Device for Inclusion and Shutdown of Condenser Installations in System of Power Supply // «Eastern European» scientific journal. Dusseldorf (Germany). 2015. - №4. Ausgabe. – PP.179-183.
11. Karimov R.Ch., Karimov I.Ch. Research of the modes of electric chains by reducing the equations of state to a standart tupe in power supply systems // «Young scientist USA» scientific journal. USA. 2016. №5. P.106-109.
12. Bobojanov M.Q., Karimov R.Ch. Elektr ta'minoti tizimida optoelektronli rezistiv zanjir-larni tadqiq qilish // «TosDTU xabarlari» jurnali. Toshkent, 2017. - №4(101). – B.53-57.
13. Bobojanov M.Q., Karimov R.Ch., Zubaydullayev M.B. Elektr ta'minoti tizimida kontaktsiz kuchlanish stabilizatorlari // Sbornik materialov III-mejdunarodnoy nauchno-praktiches-koy internet-konferentsii «Nauka i obrazovaniya v XXI veke». Kazaxstan, Astana, 2018. – S.20-25.
14. Bobojanov M.K., Usmanov E.G., Abduraimov E.H., Karimov R.Ch. Resistive time delay switches // Scientific journal «European Science Review» Austria, Vienna, 2018. - №1-2. January–February. – PP.210-212.
15. Bobojanov M.Q., Rasulov A.N., Karimov R.Ch., Sattarov X.A. Elektr ta'minoti tizimida kontaktsiz kuchlanish stabilizatorlarini tadqiq qilish // «Mihammad al-Xorazmiy avlodlari» jurnali. Toshkent, 2018. - №3(5). – B.106-109.
16. Ochildiyev A.I., Omonov F.B., Sa'dullayev M., Karimov R.Ch. Issledovanie beskontakt-nix kommutiruyushix ustroystva dlya puska elektrovvugateley v sistemax elektrosnabjeniya // Mejdunarodniy nauchniy jurnal «Put nauki». Rossiya, Volgograd, 2018. - №3(49) Mart. – S.23-25.
17. Usmonov E.G., Karimov R.Ch., Baxromov B.M. Ispol'zovanie beskontaktnix rele

napryajeniya dlya uluchsheniya kachestva elektroenergii v sistemax elektrosnabjeniya // Mejdunarodniy nauchniy jurnal «Put nauki». Rossiya, Volgograd, 2019. - №4(62) Mart. – S.23-25.

18. Sulliyev A.X., Karimov R.Ch. Elektr ta'minoti tizimida optotiristorli kontaktsiz kuchlanish relesini ishlatish // «ToshTYMI axboroti» jurnali. Toshkent, 2018. - №4. – B.149-154.

19. Karimov R.Ch., Rasulov A.N., Meliqo'ziyev M.V., Almardonov O., Rafiqov M.Z. Analysis on diode electrical circuits // International Journal of Advanced Research in Science, Engineering and Technology. India. - №6, Issue 3, March 2019 – P.8294-8298.

20. Karimov R.Ch., Usmonov E.G., Xolbekov J.A. Nochiziqli elektr zanjiridagi dinamik jarayonni “O'zgarmasni variatsiyalash” usuli yordamida tadqiq qilish // «TosDTU xabarleri» jurnali. Toshkent, 2019. - №2(107). – B.75-82.