

8-2-2019

## PARAMETERS OF COEFFICIENTS OF THE RAIL FOUR-POLE OF THE JOINTLESS RAIL CIRCUIT ACCORDING TO LOCOMOTIVE RECEIVER

R.M. Aliev  
*Tashkent Institute of Railway Engineers*

E.T. Tokhirov  
*Tashkent Institute of Railway Engineers*

M.M. Aliev  
*Tashkent Institute of Railway Engineers*

Follow this and additional works at: <https://btstu.researchcommons.org/journal>



Part of the [Engineering Commons](#)

---

### Recommended Citation

Aliev, R.M.; Tokhirov, E.T.; and Aliev, M.M. (2019) "PARAMETERS OF COEFFICIENTS OF THE RAIL FOUR-POLE OF THE JOINTLESS RAIL CIRCUIT ACCORDING TO LOCOMOTIVE RECEIVER," *Technical science and innovation*: Vol. 2019: Iss. 2, Article 6.

DOI: <https://doi.org/10.51346/tstu-01.19.2.-77-0026>

Available at: <https://btstu.researchcommons.org/journal/vol2019/iss2/6>

This Article is brought to you for free and open access by Technical Science and Innovation. It has been accepted for inclusion in Technical science and innovation by an authorized editor of Technical Science and Innovation.

## PARAMETERS OF COEFFICIENTS OF THE RAIL FOUR-POLE OF THE JOINTLESS RAIL CIRCUIT ACCORDING TO LOCOMOTIVE RECEIVER

R.M. Aliev<sup>1</sup>, E.T. Tokhirov<sup>1</sup>, M.M. Aliev<sup>1</sup>

<sup>1</sup>Tashkent Institute of Railway Engineers

### Abstract

In article questions of a conclusion of the coefficients of the equations of a rail four-polar of a jointless rail circuit are considered, taking into account uncertainty of borders where the travelling receiver which is applied now on a railway transportation is used. Mathematical modeling of four-pole coefficients by locomotive receiver is given. Analytical expressions and coefficients for calculation of the locomotive current flowing under the receiving coils and transfer resistance are derived. The scheme of a jointless rail circuit in the presence of moving units and mutual influence on each other is given. The influence of the carrier information from the traffic light in front, where it is necessary to take into account the factor of the signal level from the outgoing train, so that the information of the neighboring rail circuit would not be perceived, since there are no insulating joints. A scheme with five four poles has been developed and coefficients of these four poles have been obtained to calculate the current of the locomotive flowing under the receiving coils. Analytical expressions are obtained for determining the current for receiving by the receiving coils of a locomotive, the minimum supply voltage of an unbroken rail circuit and the transmission resistance of a rail circuit in normal operation for a locomotive receiver.

**Key words:** rail circuits, jointless rail circuits, locomotive receiver, automatic locomotive alarm system, track receiver.

Jointless rail chains [1, 3, 4, 6, 11] are especially effective when there are no traffic lights on the stage and the movement of trains is regulated only by automatic locomotive signaling (ALS) [2, 5, 8, 9, 10, 14]. In this case, the blurred boundaries of the jointless rail chains does not have practical value and only a potential track receiver can be applied [7, 12, 15]; higher requirements are imposed on the operation of the locomotive ALS receiver. The locomotive receiver is triggered by the e.m.f, which is induced in the locomotive receivers by the current in the rails of Fig. 1.

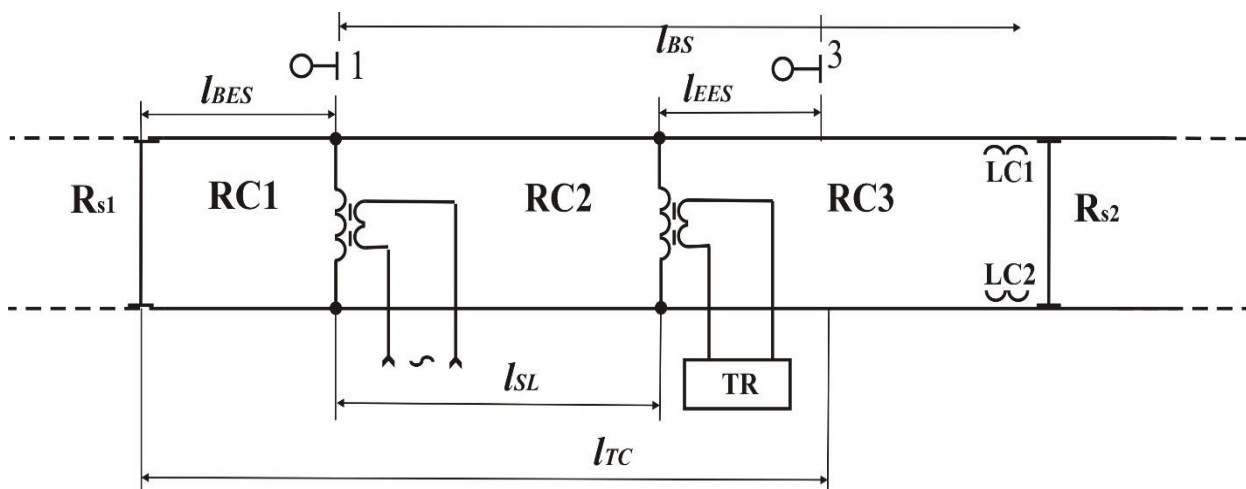
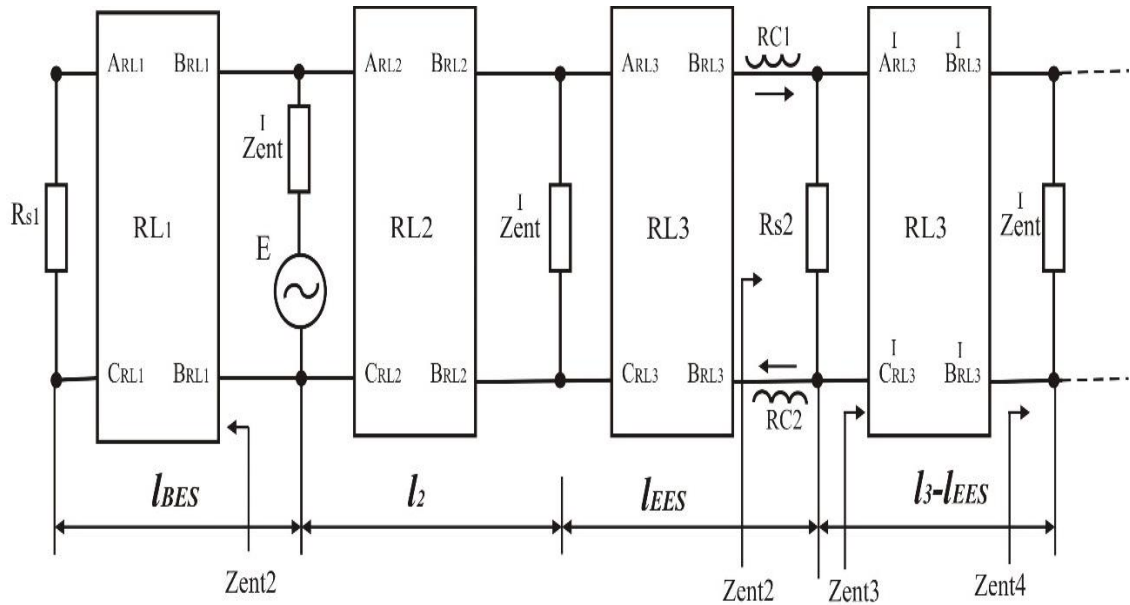

Fig. 1. Layout of the jointless rail circuit with moving units on it

When the train enters the RC3 rail circuit from the traffic light 3, a current carrying information about the condition of the RC2 rail circuit flows under the locomotive coils and, as it approaches the traffic light 3, the TR track receiver of the second rail circuit turns off and stops sending signals to the locomotive, but the signal from the locomotive starts 1st signal point. The level of this signal depends on the outgoing train on the rail circuit RC1. Therefore, when calculating this fact must be taken into account.

To derive the calculation equations, we present the circuit of rail chains [17], taking into account the above circumstances, in the form of an equivalent circuit of Fig. 2.



**Fig. 2.** Scheme of replacement of the jointless rail circuit in the presence of movable units

We transform the circuit of Fig. 2 to the circuit of Fig. 3 replacing the four-terminal RL1 and RL13 with their input resistances.

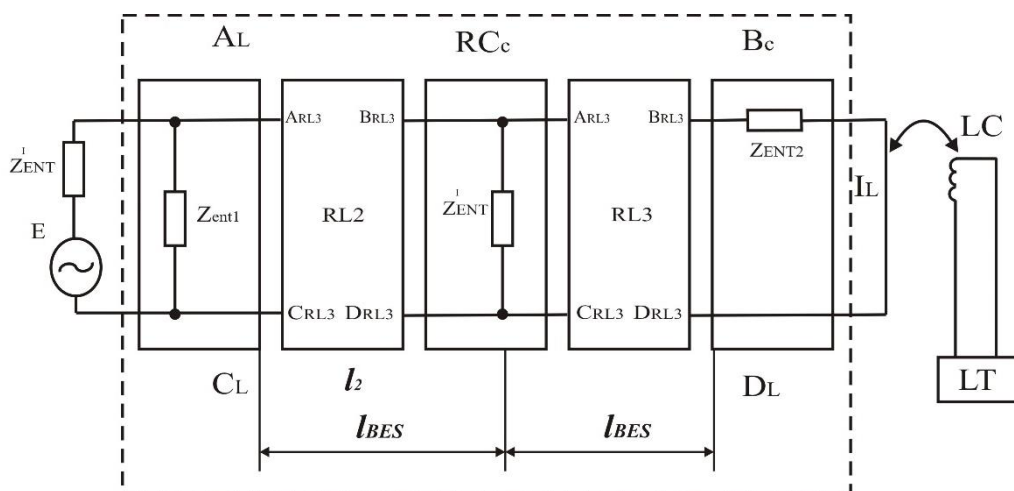

**Fig. 3.** Converted substitution scheme of a jointless rail circuit

Where

$$Z_{en1} = \frac{Z_{elr1} * sh\gamma_{lr1} l_{bes}}{ch\gamma_{lr1} l_{bes}}, \quad (1)$$

$$Z_{en2} = \frac{R_{m2} * Z_{en3}}{R_{m2} + Z_{en3}}, \quad (2)$$

$$Z_{en3} = \frac{A_{lr3}^I * Z_{en4} + B_{lr3}^I}{C_{lr3}^I * Z_{en4} + D_{lr3}^I}, \quad (3)$$

$$Z_{en4} \approx Z_{elr4}; \quad (4)$$

$$A_{lr3}^I = ch\gamma_{lr3}(l_3 - l_{ees}); B_{lr3}^I = Z_{elr3} sh\gamma_{lr3}(l_3 - l_{ees}); \quad (5)$$

$$C_{rl3}^I = \frac{1}{Z_{erl3}} sh\gamma_{rl3}(l_3 - l_{ees}); D_{rl3}^I = ch\gamma_{rl3}(l_3 - l_{ees}); \quad (6)$$

$Z_{erl4}$  - wave impedance of the fourth rail line;

$\gamma_{rl3}$  - wave propagation coefficient of the third rail line;

$$A_{rl3} = ch\gamma_{rl3} l_{ees}; B_{rl3} = Z_{erl3} sh\gamma_{rl3} l_{ees}; \quad (7)$$

$$C_{rl3} = \frac{1}{Z_{erl3}} sh\gamma_{rl3} l_{ees}; D_{rl3} = ch\gamma_{rl3} l_{ees}; \quad (8)$$

$$A_{rl2} = ch\gamma_{rl2} l_{rl2}; B_{rl2} = Z_{erl2} sh\gamma_{rl2}; \quad (9)$$

$$C_{rl2} = \frac{1}{Z_{erl2}} sh\gamma_{rl2} l_{rl2}; D_{rl2} = ch\gamma_{rl2} l_{rl2}; \quad (10)$$

$Z_{erl2}$  - wave impedance of the main rail line;

$\gamma_{rl2}$  - wave propagation coefficient of the main rail line.

A circuit with five four-terminal circuits is obtained, multiplying the coefficients of these four-terminal circuits, we obtain coefficients for calculating the current flowing under the receiving coils of the locomotive.

$$\begin{vmatrix} A_l & B_l \\ C_l & D_l \end{vmatrix} = \begin{vmatrix} 1 & 0 \\ \frac{1}{Z_{en1}} & 1 \end{vmatrix} * \begin{vmatrix} A_{rl2} & B_{rl2} \\ C_{rl2} & D_{rl2} \end{vmatrix} * \begin{vmatrix} 1 & 0 \\ \frac{1}{Z_{be}^I} & 1 \end{vmatrix} * \begin{vmatrix} A_{rl3} & B_{rl3} \\ C_{rl3} & D_{rl3} \end{vmatrix} * \begin{vmatrix} 1 & Z_{en2} \\ 0 & 1 \end{vmatrix}$$

$$A_l = A_{rl3} \left( A_{rl2} + \frac{B_{rl2}}{Z_{be}^I} \right) + B_{rl2} * C_{rl3}; \quad (11)$$

$$B_l = Z_{en2} \left[ A_{rl3} \left( A_{rl2} + \frac{B_{rl2}}{Z_{ent}^I} \right) + B_{rl2} * C_{rl3} \right] + B_{rl3} \left( A_{rl2} + \frac{B_{rl2}}{Z_{ent}^I} \right) + B_{rl2} * D_{rl3}; \quad (12)$$

$$C_l = A_{rl3} \left[ \frac{A_{rl2}}{Z_{en1}} + C_{rl2} + \frac{1}{Z_{ent}^I} \left( \frac{B_{rl2}}{Z_{en1}} + D_{rl2} \right) \right] + C_{rl3} \left( \frac{B_{rl2}}{Z_{en1}} + D_{rl2} \right); \quad (13)$$

$$D_l = Z_{en2} \left\{ A_{rl3} \left[ \frac{A_{rl2}}{Z_{en1}} + C_{rl2} + \frac{1}{Z_{ent}^I} \left( \frac{B_{rl2}}{Z_{en1}} + D_{rl2} \right) \right] + \right.$$

$$+C_{rl3} \left( \frac{B_{rl2}}{Z_{en1}} + D_{rl2} \right) \} + B_{rl3} \left[ \frac{A_{rl2}}{Z_{en1}} + C_{rl2} + \frac{1}{Z_{ent}^I} \left( \frac{B_{rl2}}{Z_{en1}} + D_{rl2} \right) \right] + D_{rl3} \left( \frac{B_{rl2}}{Z_{en1}} + D_{rl2} \right); \quad (14)$$

Substituting the values of the quantities

$Z_{en1}, Z_{en2}, Z_{en3}, Z_{en3}, A_{rl3}^I, B_{rl3}^I, C_{rl3}^I, D_{rl3}^I, A_{rl2}, B_{rl2}, C_{rl2}, D_{rl2}$  in equations (11-14), we get:

$$A_l = ch\gamma_{rl3} l_{ees} \left( ch\gamma_{rl2} l_{rl2} + \frac{Z_{erl2} sh\gamma_{rl2}}{Z_{ent}^I} \right) + \rightarrow \\ + Z_{erl2} sh\gamma_{rl2} * \frac{1}{Z_{erl3}} sh\gamma_{rl3} l_{ees}; \quad (15)$$

$$B_l = Z_{en2} [ch\gamma_{rl3} l_{ees} (ch\gamma_{rl2} l_{rl2} + \frac{Z_{erl2} sh\gamma_{rl2}}{Z_{ent}^I}) + \rightarrow \\ + Z_{erl2} sh\gamma_{rl2} * \frac{1}{Z_{erl3}} sh\gamma_{rl3} l_{ees}] + Z_{erl3} sh\gamma_{rl3} l_{ees} * \rightarrow \\ * \left( ch\gamma_{rl2} l_{rl2} + \frac{Z_{erl2} sh\gamma_{rl2}}{Z_{ent}^I} \right) + Z_{erl2} sh\gamma_{rl2} * ch\gamma_{rl3} l_{ees}; \quad (16)$$

$$C_l = ch\gamma_{rl3} l_{ees} \left[ \frac{ch\gamma_{rl2} l_{rl2}}{Z_{ent}^I} + \frac{1}{Z_{erl2}} sh\gamma_{rl2} l_{rl2} + \rightarrow \right. \\ \left. + \frac{1}{Z_{ent}^I} \left( \frac{Z_{erl2} sh\gamma_{rl2}}{Z_{ent}^I} + ch\gamma_{rl2} l_{rl2} \right) \right] + \frac{1}{Z_{erl3}} sh\gamma_{rl3} l_{ees} * \left( \frac{Z_{erl2} sh\gamma_{rl2}}{Z_{ent}^I} + ch\gamma_{rl2} l_{rl2} \right); \quad (17)$$

$$D_l = Z_{en2} \left\{ ch\gamma_{rl3} l_{ees} \left[ \frac{ch\gamma_{rl2} l_{rl2}}{Z_{ent}^I} + \frac{1}{Z_{erl2}} sh\gamma_{rl2} l_{rl2} + \rightarrow \right. \right. \\ \left. \left. + \frac{1}{Z_{ent}^I} \left( \frac{Z_{erl2} sh\gamma_{rl2}}{Z_{ent}^I} + ch\gamma_{rl2} l_{rl2} \right) \right] + \frac{1}{Z_{erl3}} sh\gamma_{rl3} l_{ees} * \rightarrow \right. \\ \left. * \left( \frac{Z_{erl2} sh\gamma_{rl2}}{Z_{ent}^I} + ch\gamma_{rl2} l_{rl2} \right) \right\} + Z_{erl3} sh\gamma_{rl3} l_{ees} * \rightarrow \\ * \left[ \frac{ch\gamma_{rl2} l_{rl2}}{Z_{ent}^I} + \frac{1}{Z_{erl2}} sh\gamma_{rl2} l_{rl2} + \frac{1}{Z_{ent}^I} \left( \frac{Z_{erl2} sh\gamma_{rl2}}{Z_{ent}^I} + ch\gamma_{rl2} l_{rl2} \right) \right] + \rightarrow \\ + ch\gamma_{rl3} l_{ees} \left( \frac{Z_{erl2} sh\gamma_{rl2}}{Z_{ent}^I} + ch\gamma_{rl2} l_{rl2} \right). \quad (18)$$

It is known that

$$I_l = \frac{U_{min}}{Z_{tl}}; \quad (19)$$

$$U_{min} = U_1 + I_1 * Z_{ent}^I; \quad (20)$$

$$U_1 = I_l * B_l; I_1 = I_l * D_l, \quad (21)$$

where from

$$U_{min} = I_l * B_l + I_l * D_l * Z_{ent}^I ; \quad (22)$$

$$I_l = \frac{U_{min}}{B_l + D_l * Z_{ent}^I} ; \quad (23)$$

$$Z_{tl} = B_l + D_l * Z_{ent}^I, \quad (23)$$

where  $Z_{tl}$  - transmission resistance of the rail circuit in normal mode for a locomotive receiver.

The obtained analytical expressions make it possible to analyze and synthesize continuous rail circuits for a locomotive receiver when developing rail circuits without insulating joints on both speed and high-speed sections of the railway.

### References

1. Railway Signaling & Interlocking. International Compendium. Editors: Gregor Theeg, Sergei Vlasenko. A DVV Media Group publication. Eurailpress, 2009, - 448 p.
2. Zorin V.I. Microprocessor-based locomotive safety systems for new generation trains / V.I. Zorin, E.E. Shuhina, P.V. Titov // The world's railroads. – 2003. №7. –P. 61-69.
3. Lisenkov V.M., Bestemyanov P.F., Leushin V.B. and others. Train traffic control systems on the tracks. Part1; edited by Lisenkov V.M – M.: GOU «Training and Methodological Centre for Railway Education». Transport book, 2009. – 160 p.
4. Lisenkov V.M., Bestemyanov P.F., Leushin V.B. and others. Train traffic control systems on the tracks. Part2; edited by Lisenkov V.M – M.: GOU «Training and Methodological Centre for Railway Education». Transport book, 2009. — 175 c.
5. Tilk I.G. New automatic and telemechanical devices for railway transport. – Yekaterinburg: UrGUPS, 2010. – 168 p.
6. Fedorov N.E. Modern autoblocking systems with tonal rail circuits. - Samara, 2004. -130 p.
7. Exclusion of the passage of the forbidden traffic light signal: new technique and technology / E.N. Rosenberg [et al.] // Automatics, communication, informatics: Popular industrial and technical journal. - 2008. - N 2. - p. 10-11 . - ISSN 0005-2329.
8. Intelligent Transport Systems (ITS) for sustainable mobility. UN, Economic Commission for Europe, UNECE. Geneva, February 2012. 120 p.
9. Intelligent Transport Systems (ITS): an area to be strengthened in the Transport sector. [http://www.unece.org/trans/theme\\_its.html](http://www.unece.org/trans/theme_its.html)
10. Boynik A.B., Koshevoy S.V., Panchenko S.V., Sotnik V.A. Interval regulation systems of trains movement on the spans. Textbook. - Kharkov: UkrGAZhT, 2005. 256 p.
11. Vasilenko, M.N.; Denisov, B.P.; Kultin, V.N.; Rastegaev, S.N. Calculation of the parameters and check of the operation of the jointless tonal rail circuits (in Russian) // Problematics of the transport systems. News of PGUPS. 2006. №2. p.101 – 109.
12. Kulik P.D., Ivankin N.S., Udovikov A.A. Tone rail circuits in RCA systems: construction, adjustment, maintenance, troubleshooting, increase of operational reliability. -

---

Kiev: Publishing house "Manufacture", 2004. – 288 p. – II.57. ISBN 966-8173-02-3

13. Lisenkov V.M., Vanshin A.E., Katkov M.V. Methods of increasing the safety of the rail circuits functioning. // Journal "Automatics, communication and informatics".- M.,2010.-№4. P.8-10.

14. Lisenkov V.M. Statistical Theory of Traffic Safety (Textbook for HEIs) of the Ministry of Railways of the Russian Federation, Russian Academy of Sciences M.: VINITI RAS, 1999. – 332 p.

15. Lisenkov V.M., Belyakov I.V., Kovalev I.P., Sukhanova N.V. Microelectronic system of automatic blocking AB-E1. // "Automatics, telemechanics and communication" magazine.- M.,1996. - № 5. – p. 2 - 6.

16. Overview of existing, under construction and planned high-speed lines in the world // World Railways. - 2007. - № 12. - p. 9-15.

17. Calculation of parameters and check of the performance of the jointless tonal rail circuits / M. N. Vasilenko, B. P. Denisov, V. B. Kultin, S. N. Rasstegaev // Izvestiya St. Petersburg State University of Railway Transport. - 2006. -№ 2. - C. 104-112.

18. Safe and precise localisation of Railway Objects GNSS Multisensor based architecture for highly accurate and safe object localisation in railways [ presentation ] / E. Schnieder, R. Schild, U. Becker, A. Brand, T. Freissler // SmartRail 4.0 [Electronic resource]. 2018. URL: [https://smartrail40.ch/download/downloads/STech2018\\_Sitges\\_Barcelona\\_vRS.pdf](https://smartrail40.ch/download/downloads/STech2018_Sitges_Barcelona_vRS.pdf).

19. Precise and reliable localization as a core of railway automation (Rail 4.0) [Электронный ресурс] / M. Hutchinson, J. Marais, E. Masson, J. Mendizabal, M. Meyer zu Horste // International Congress on High-speed Rail: technologies and long term impacts, Oct 2017, Madrid, Spain. 2017. 10p. id: hal-01662758.

20. Hintze P., Pruter F. “But that’s not the kilometer in the plan!” – the potential of georeferenced railway infrastructure data // Signal+Draht. 2018. No 11. S. 6–15.

21. Subset-026 v360 System Requirement Specification [Электронный ресурс] сайт проекта. URL: [https://www.era.europa.eu/node/641/211\\_en](https://www.era.europa.eu/node/641/211_en).

22. Senesi F., Marzilli E. ETCS European Train Control System. Development and implementation in Italy. Roma : CIFI, 2007. 316 p.

23. Study on the architecture of on-board radio communication equipment. Final report / European Union Agency for Railways: FR01T17J09\_ERA\_OP31\_RP\_008. 2017. URL: [https://www.era.europa.eu/sites/default/files/activities/docs/study\\_on\\_architecture\\_on-board\\_radio\\_equipment\\_en.pdf](https://www.era.europa.eu/sites/default/files/activities/docs/study_on_architecture_on-board_radio_equipment_en.pdf).