

8-2-2019

PROBLEMS OF THE EFFICIENCY OF FIBER OPTIC COMMUNICATION LINES

K.T. Dadamatova

Tashkent University of information technologies

A.M. Nazarov

Tashkent State Technical University

N. N Gerasimenko

Moscow Institute of Electronic Technology

Follow this and additional works at: <https://btstu.researchcommons.org/journal>



Part of the [Engineering Commons](#)

Recommended Citation

Dadamatova, K.T.; Nazarov, A.M.; and Gerasimenko, N. N (2019) "PROBLEMS OF THE EFFICIENCY OF FIBER OPTIC COMMUNICATION LINES," *Technical science and innovation*: Vol. 2019: Iss. 2, Article 5.

DOI: <https://doi.org/10.51346/tstu-01.19.2.-77-0025>

Available at: <https://btstu.researchcommons.org/journal/vol2019/iss2/5>

This Article is brought to you for free and open access by Technical Science and Innovation. It has been accepted for inclusion in Technical science and innovation by an authorized editor of Technical Science and Innovation.

PROBLEMS OF THE EFFICIENCY OF FIBER OPTIC COMMUNICATION LINES

K.T. Dadamatova¹, A.M. Nazarov², N. N. Gerasimenko³*Tashkent University of information technologies¹**Tashkent State Technical University²**Moscow Institute of Electronic Technology³***Abstract**

The article presents the results of solving the problem of attenuation of an optical signal in fiber-optic communication lines. Widely used modern technical solutions of intermediate amplification-regenerative nodes of fiber-optic communication lines are described. The advantages and disadvantages of existing intermediate fiber optic amplifiers are presented. The benefits of optoelectronic signal regenerators include a full restoration of the original properties of the optical signal. The optoelectronic regenerator allows to limiting the amount of internal and external optical noise by acceptable values, but increases and increases the cost of building optical fiber connections. Optical signal amplifiers are also used to increase the range of fiber-optic communication lines. The main advantage of intermediate fiber optic amplifiers is their relatively simple design and, consequently, low cost, as well as high cost of losses and power output. The technical function of the developed fiber optic amplifier is to create a signal and power amplifier that is evenly distributed inside the fiber located in the region of the fiber containing the fluorescent additive. The characteristics, functional and structural diagrams of an optical repeater with erbium amplifiers are shown in detail. The design features of the construction and the principle of operation of the erbium amplifier are described.

Key words: *optical amplifier, optical fiber, doped fiber, optoelectronic regenerator, configuration, optical signal, photo detector, laser.*

In fiber-optic communication lines (FOCL), the optical signal gradually attenuates due to absorption and scattering processes. The signal-to-noise ratio decreases and the reliability of the transmitted data is violated. The noise signals operating in the optical link of the fiber optic link, by their origin, can be associated with:

- the noise component generated in the transmitter or transmitting fiber (they arrive at the photo detector with an input signal);
- intermediate optical amplifiers;
- photo detector (receiver).

To eliminate the influence of noise, intermediate fiber-optic reinforcement-regenerative nodes are used. To date, two technical solutions of intermediate fiber-optic fiber reinforcement-regenerative units [1] are widely used:

1. Optoelectronic signal regenerators [2]. In optoelectronic regenerators, the weak optical signal received by the photodetector after passing through a portion of the fiber optic transmission system (FOTS) is converted into an electric one, amplified, then an electric digital signal is generated, which is again converted into the optical range by a transmitting laser diode and introduced into the next segment of the fiber optic tract [3]. The length of the site without regeneration reaches 50–100 km. The advantages of optoelectronic signal regenerators include the complete restoration of the initial characteristics of the optical signal. The optoelectronic regenerator allows you to limit the amount of internal and external optical noise to acceptable values, but complicates and increases the cost of building fiber optic links. The optoelectronic

regenerator contains a receiver, an electronic amplifier and a transmitter, which makes it a complex and expensive device. The complexity, relatively low reliability and high cost of optoelectronic regenerators prevents the widespread use of FOTS [4,5]. Thus, the use of optoelectronic regenerators complicates the construction of amplification-regenerative nodes and dramatically increases the cost of fiber optic links.

2. To increase the range of fiber-optic communication lines (FOCL), optical signal amplifiers (OSA) (repeaters) are also used [6]. The disadvantages of optoelectronic regenerators are partially eliminated using optical quantum amplifiers based on active fibers [1]. Usually, single-mode fibers doped with rare-earth elements (in most cases erbium) with metastable electronic levels, which are pumped by pump laser radiation through a directional coupler with the formation of an active (amplifying) medium (erbium-doped fiber amplifier), an erbium-doped fiber amplifier (usually, are used for these purposes) EDFA)) [7,8]. In this medium, a signal at a wavelength in the fluorescence band is not attenuated, but amplified due to the known effect of stimulated emission, i.e., an optical signal is amplified. Currently, doped fiber optical amplifiers are intermediate fiber optic amplifiers (FOA) that are dominant [9]. Laser diode opamps competing with them are still inferior to them due to the high cost of production, polarization sensitivity, and a high level of crosstalk. The main advantage of intermediate fiber-optic amplifiers is their relatively simple design and, consequently, low cost, as well as a large value of the gain and output power. The disadvantages of existing FOA are those [10]:

1) The main problem in the construction of fiber optic amplifiers is the fundamentally unrecoverable noise source - amplified spontaneous emission (ASE). The presence of this process leads to the fact that the minimum possible noise figure of the FOA is at least 3 dB. The fundamental fatigue of this noise source is explained by the fact that spontaneous emission (noise) already occurs in the fiber upon pumping, and this process does not depend on the signal amplification effect, which requires high pump levels (the presence of an inverse population), i.e., the noise is not equal to zero at any fiber gain [11]. At a low signal level, the noise gain is equal to the gain of a weak signal and represents the unsaturated gain of the optical amplifier, which should be as high as possible (for modern designs 30–50 dB) for the amplification of the transmitted optical signal. Therefore, during the amplification of the optical signal of small amplitude occurs, the input noise and ASE noise are amplified with a maximum gain coefficient. Most of the proposed technical solutions [12] for low-noise FOA are based on optimization of the unsaturated gain coefficient of FOA depending on the average level or other parameters of the amplified signal.

2) FOA, working in the linear amplification mode, amplifies the noise components coming from other sources along with the amplified signal, for example, noise due to residual mode, polarization or spectral dispersion, noise of spontaneous emission from a transmitting laser diode, and others [13].

3) The initial characteristics of the optical signal are not restored completely by the optical amplifier-regenerator. Thus, it is fundamentally impossible to completely get rid of the noise component associated with ASE noise [14] of the HEU itself, as well as noise due to residual mode, polarization, or spectral dispersion, noise of spontaneous emission from a transmitting laser diode, etc. One of the most important characteristics of any amplifier or regenerator for fiber optic systems is the noise figure reduced to the input [15].

It is known that optical fibers having a doped core obtained using certain substances (such as

rare-earth metal ions) have stimulated emission characteristics suitable for use as laser sources and optical amplifiers [16]. These fibers are capable of being fed by a light source of a certain wavelength, called the pump wavelength, which can bring the dopant atoms into an excited state, or the pump band, from which the atoms spontaneously pass into a state of laser radiation in a very short period of time, in which they remain for a relatively long time .

When a light signal having a wavelength corresponding to this state of laser radiation passes through a fiber having a large number of atoms in an excited state at the level of laser radiation, the signal causes the excited atoms to transition to a lower level, and the emitted light has the same wavelength as and signal. Therefore, a fiber of this type can be used to amplify the signal, in particular, to create amplifiers adapted to return the transmitted optical signal to a high level after a long movement along the fiber in the communication line.

The fluorescent additive responsible for amplifying the transmitted signal is concentrated in the optical core, and the fiber in the known amplifiers is designed so that the pumping energy is also contained in this region, so that it can be fully used to excite the fluorescent additive at the laser radiation level. However, since part of the energy of the transmitted signal is transmitted to the fiber outside the region in which the fluorescent additive and pump energy are present, this leads to the fact that only part of this signal is in the region of the fiber in which it can be amplified.

The technical task of the fiber-optic amplifier under development is the creation of an amplifier in which the energy of the transmitted signal and the pump energy have essentially the same distribution in the cross section of the active fiber, and are also concentrated in the region of the fiber in which the fluorescent additive is present.

The solution to the above problem is achieved by the fact that in the amplifier, the active optical fiber, which allows for straight-mode contouring, provides single-mode light distribution at the wavelength of the transmitted signal and multi-mode light propagation at the pump wavelength, in a section longer than 70% of its entire length, made conformation, and the bending radius in the bent section corresponds to the propagation in the fiber of only the fundamental mode at the pump wavelength.

The bending radius of the curved active fiber is in the range of 20-140 mm, while the preferred bending radius of the active fiber is in the range of 35-100 mm.

The wavelength at the output of the signal is in the range 1520 - 1570 nm, and the pump wavelength is 980 nm (accuracy 10 nm), while the fluorescent additive in the active fiber is erbium.

Due to the fact that in this work all the necessary results were achieved, it was possible to obtain the necessary coefficient, which allows to obtaining the minimum allowable energy when using the wavelength and the desired gain [3, 4].

EDFA amplifiers are direct amplified optical radiation, without converting them into electrical signals and vice versa, while the long wavelength range almost exactly matches the transparency of a quartz optical fiber (they can operate at several wavelengths simultaneously - Fig. 1). Thanks to the advent of communication line amplifiers based on DWDM systems, they have become economically attractive.

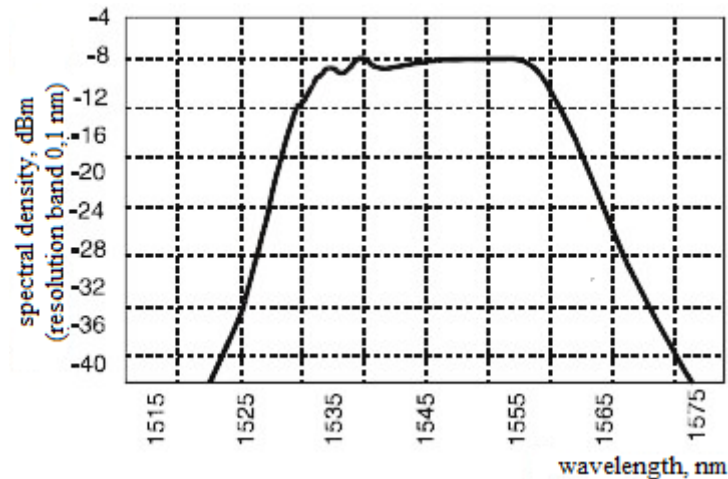

Fig. 1. EDFA on wavelength

The EDFA amplifier consists of a piece of fiber doped with erbium. In such a fiber, signals of certain wavelengths can be amplified due to the energy of external pump radiation. In the simplest EDFA designs, amplification takes place over a fairly narrow wavelength range — from about 1525 to 1565 nm. At these 40 nm, several dozens of DWDM channels fit.

If a laser emitter emits in a fiber with a typical attenuation, 0.2 dB / km in the wavelength region of 1550 nm, the signal power is +16 dBm, then after passing 80 km the power of this signal will drop to the level of 0dBm. If the laser generates a signal with a power of 0dBm, then after passing the same 80 km it will drop to the level of -16 dBm.

The functional diagram of the FOA is shown in Fig. 2.

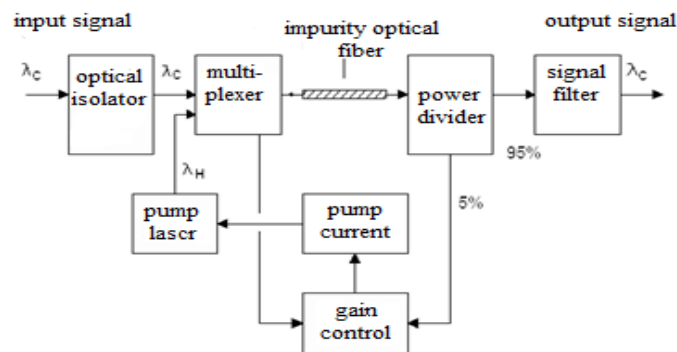

Fig. 2. FOA Functional Diagram

The basis of the FOA design is optical fiber mixed with rare-earth metal. For example, erbium (Er) corresponds to amplification wavelengths of 1.53-1.55 μm . The length of the fiber with impurity is from 20 to 50 m.

In order for the fiber to become an amplifying medium, it is pumped with λ_H radiation from a separate laser. Two-way pumping from two lasers is also possible. The gain control system controls the laser pump current thanks to feedback set via a power divider. The amplified signal λ_c and pump waves λ_H are combined in the multiplexer and sent to the optical fiber with an impurity, where the signal power increases. Most (95%) of the power of the amplified signal passes through the filter to the output. The filter cuts off the pump wave's λ_n and noise outside the signal frequency band [17]. The optical isolator eliminates the penetration of the signals

reflected in the amplifier into the incoming optical line.

FOAs are used, as a rule, on long lines where transmission occurs at a wavelength of 1.55 microns. Erbium FOAs are used to increase the length of the transmission section. Consider their work and characteristics.

Erbium ions (Er^{3+}) are placed in the fiberglass core. Waves of 1480, 980, 800, 670 and 521 nm. 1480 nm and 980 nm are really used. This is due to several reasons: the efficiency of high power semiconductor lasers, low attenuation of the optical fiber, and low requirements for the accuracy of the pump wavelength [18].

For clarity, some characteristics are shown in Figs. 3 and 4. These are the dependences of the gain on the length of the active fiber, pump power, and output signal.

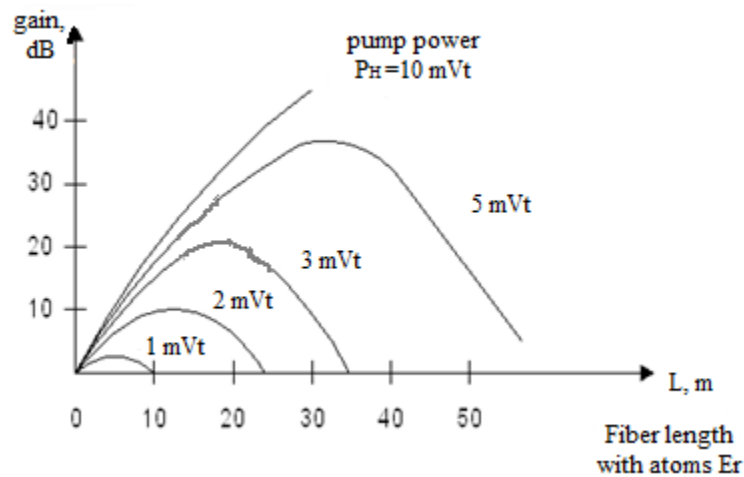

Fig. 3. Erbium amplifier gain graphs versus fiber length and pump power

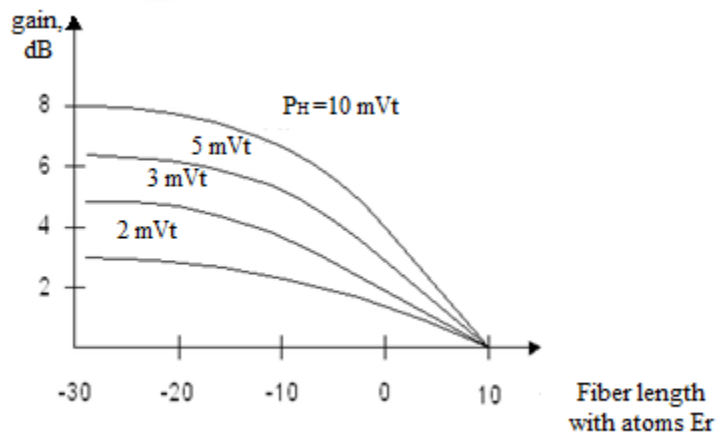

Fig. 4. Amplification graphs of an erbium amplifier depending on the output signal

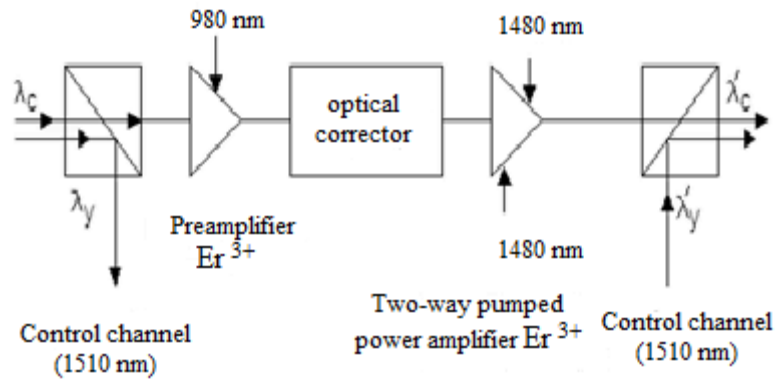

Fig. 5. Block diagram of an optical repeater with erbium amplifiers

In the optical repeater circuit, a control channel is allocated that is organized on a separate carrier wave λ_Y . The preamplifier provides maximum signal to noise ratio. The power amplifier has two-sided pumping at a wavelength of 1480 nm, which creates the maximum linearity of the gain characteristics. An optical corrector compensates for optical pulse distortion due to chromatic dispersion in single-mode fiberglass. However, the corrector does not eliminate the effect of polarization mode dispersion (PMD), for the compensation of which the use of a dynamic controlled compensator is necessary.

FOA can have a large non-uniformity of the amplitude-frequency characteristic, which is unacceptable for multi-wave transmission systems (systems with WDM). A number of solutions are known for smoothing the frequency response of erbium amplifiers and expanding their gain frequency bands, for example, by using automatically tunable attenuators for each transmission wave [19].

On the other hand, useful results, i.e. an increase in the gain in comparison with amplifiers having a single-mode active fiber can also be obtained by using an active fiber bent only over a portion of the fiber length, if necessary to meet requirements of a different origin. But, provided that the portion of the bent fiber along the bend radius corresponding to the propagation of the main mode of pump power alone is more than 70% of the entire fiber length [20].

In conclusion, it should be noted that EDFA amplifiers are independent of the protocols used for data transmission and data transfer rates. This feature of EDFA is another argument in favor of their use in DWDM systems, which often combine many heterogeneous channels. Also, EDFAs do not depend on the type of signal, whether it is discrete digital or analog. Therefore, EDFA amplifiers are also used in cable television networks, in which, due to their specifics, the requirements for signal power and its quality (for example, signal-to-noise ratio) are increased.

References

1. Pixtin A.N. Kvantovaya i opticheskaya elektronika. Komponenti VOLS. – M.: Abris, 2015. – pages -656.
2. Liu, C., Deng, L., Liu, D. & Su, L. Modeling of a single multimode fiber imaging system. arxiv:1607.07905. 2018. pages -310.
3. Turtaev, S. et al. High-fidelity multimode fibre-based endoscopy for deep-brain in vivo imaging. Light. Appl. 2018. № 7. pages -92.
4. Takagi, R., Horisaki, R. & Tanida, J. Object recognition through a multimode fiber. Opt. Rev. 2017. №24. pages -117–120.

5. Borhani, N., Kakkava, E., Moser, C. & Psaltis, D. Learning to see through multimode fibers. *Optica*. 2018. №5. pages -960.
6. Rahmani, B., Loterie, D., Konstantinou, G., Psaltis, D. & Moser, C. Multimode optical fiber transmission with a deep learning network. *Light Appl.* 2018. № 7 pages -69.
7. Fan, P., Zhao, T. & Su, L. Deep learning the high variability and randomness inside multimode fibres. *Arxiv:1807.09351*. 2018. pages -112-120.
8. Cheng PK, et al. Ultrafast soliton and stretched-pulse switchable mode-locked fiber laser with hybrid structure of multimode fiber based saturable absorber. *Scientific Reports*. 2019. doi: 10.1038/s41598-019-46658-y.
9. Wang L, et al. Femtosecond mode-locked fiber laser at 1 μm via optical microfiber dispersion management. *Scientific Reports*. 2018. pages -8-473.
10. Zhang Y, et al. Photonics and optoelectronics using nano-structured hybrid perovskite media and their optical cavities. *Phys. Reports*. 2019. pages -1–51.
11. Luo X, et al. Simple open-cavity pulsed Brillouin fiber laser with broadband supercontinuum generation. *Appl. Phys. B*. 2017. pages -123-259.
12. Muniz-Cánovas P, Barmenkov YO, Kir'yanov AV, Cruz JL, Andrés MV. ASE narrow-band noise pulsing in erbium-doped fiber amplifier and its effect on self-phase modulation. *Opt. Express*. 2019. №27. pages -8520–8528.
13. Keppler, Sebastian; Sävert, Alexander; Körner, Jörg; Hornung, Marco; Liebetrau, Hartmut; Hein, Joachim; Kaluza, Malte Christoph. "The generation of amplified spontaneous emission in high-power CPA laser systems". *Laser & Photonics Reviews*. 2016. № 10. pages -264–277.
14. Iqbal, M. A., Al-Khateeb, M. A. Z., Krzczanowicz, L., Phillips, I. D., Harper, P. & Forsyjak, W. Linear and Nonlinear Noise Characterisation of Dual Stage Broadband Discrete Raman Amplifiers. *Journal of Lightwave Technology*. 2019. № 34. pages -3679-3688.
15. Iqbal, M. A., Krzczanowicz, L., Phillips, I. D., Harper, P. & Forsyjak, W. Noise Performance Improvement of Broadband Discrete Raman Amplifiers Using Dual Stage Distributed Pumping Architecture. *Journal of Lightwave Technology*. 2019. №37. pages -3665-3671.
16. Dario Piori, Luca Bertignono, Antonino Nespola, Fabrizio Forghieri, Marco Mazzini, and Roberto Gaudino. "Bidirectional 4-PAM to Double Per-Fiber Capacity in 2-km Intra-Datacenter Links". In: *IEEE Photonics Journal* 10.2. 2018. pages -1–10.
17. Dario Piori, Luca Bertignono, Antonino Nespola, Fabrizio Forghieri, and Gabriella Bosco. "Comparison of Probabilistically Shaped 64QAM With Lower Cardinality Uniform Constellations in Long-Haul Optical Systems". In: *Journal of Lightwave Technology* 36.2. 2018. pages -501–509.
18. Dario Piori, Chris Fludger, and Roberto Gaudino. "Comparing DMT Variants in Medium-Reach 100G Optically Amplified Systems". In: *Journal of Lightwave Technology* 34.14. 2016. pages -3389–3399.
19. A. Almukhtar, A. Al-Azzawi, S. DASb, A. Dhar, M. Paul, Z. Jusoh, et al. Efficient L-band erbium-doped fiber amplifier with zirconia-Yttria-Aluminum co-doped silica fiber. *J Non-Oxide Glasses* № 10. 2018. pages - 65-70.
20. A. Markom, M.C. Paul, A. Dhar, S. Das, M. Pal, S.K. Bhadra, et al. Performance

comparison of enhanced Erbium–Zirconia–Yttria–Aluminum co-doped conventional erbium-doped fiber amplifiers. *Optik-Int J Light Electron Opt*, 132. 2017. pages- 75-79.