

6-11-2019

DEVELOPMENT OF A HIGH-SPEED ALGORITM OF NEURO-LOGICAL CONCLUSION

I.H. Siddikov

Tashkent State Technical University

D.B. Yadgarova

Tashkent State Technical University

Follow this and additional works at: <https://btstu.researchcommons.org/journal>



Part of the [Engineering Commons](#)

Recommended Citation

Siddikov, I.H. and Yadgarova, D.B. (2019) "DEVELOPMENT OF A HIGH-SPEED ALGORITM OF NEURO-LOGICAL CONCLUSION," *Technical science and innovation*: Vol. 2019: Iss. 1, Article 6.

DOI: <https://doi.org/10.51346/tstu-01.19.1.-77-0014>

Available at: <https://btstu.researchcommons.org/journal/vol2019/iss1/6>

This Article is brought to you for free and open access by Technical Science and Innovation. It has been accepted for inclusion in Technical science and innovation by an authorized editor of Technical Science and Innovation.

ELECTRICAL AND COMPUTER ENGINEERING

UDC 681.60-50

DEVELOPMENT OF A HIGH-SPEED ALGORITHM OF NEURO-LOGICAL CONCLUSION

I.H. Siddikov¹, D.B. Yadgarova¹

¹Tashkent State Technical University

Abstract

One of the ways to increase the efficiency of the process of managing continuous dynamic objects is to develop new or improve existing control systems based on modern methods involving the achievements of information technology. The article deals with the creation of highly efficient control algorithms for technological objects, operating in conditions of uncertainty, designed to manage real-life objects. An algorithm is proposed for the structural-parametric adaptation of the PID parameters (proportional-integral-differential) -regulator, which allows to reduce the number of iterations in the learning process of the fuzzy-logical inference algorithm by reducing empty solutions. To determine the empty solutions, hybrid algorithms are used, which include modernized genetic and immune algorithms, which in turn allow you to configure the adaptation parameters of artificial neural network models. A block diagram of an automated control system for executive mechanisms is proposed, which includes a block for adapting the correction of not only parameters, but also the structure of the control system, which allows to reduce the error in the results of training a neuro-fuzzy network from 8 to 1%. The proposed algorithm is simple to implement on microcontrollers, which allows it to be implemented in the tasks of process control in the conditions of information uncertainty in real conditions at the operation stage.

Key words: *fuzzy-logical inference, algorithm, fuzzy variables, iterations, adaptation, controller synthesis.*

One of the main requirements for modern technological facilities is the presence of high-speed modes of operation of technological units. Recently, the so-called fuzzy control algorithms have increasingly been used in process control systems. Regulators built on the basis of this innovative concept are, in some cases, capable of providing higher transient quality indicators as compared to classical regulators. In addition, using the synthesis technology of fuzzy control algorithms, it is possible to optimize complex control loops without conducting comprehensive mathematical research.

The development of a control system for many technological processes capable of supporting the main operating parameters within specified limits is a complex multi-criteria optimization task in the conditions of uncertainty in the operating characteristics of the control object and environmental parameters. To solve such a difficult task, the introduction of technology for the development of intelligent control systems based on a fuzzy controller with adaptive properties is promising.

Changing the parameters of the functional converter allows you to adjust both the dynamic and static characteristics of control systems. This structure of the controller, combined with the

optimal choice of fuzzy controller parameters, allows for adaptive control systems for uncertain and non-stationary mechanisms to be implemented with a minimum of settings, regardless of their structure.

Currently, in automated process control systems based on traditional mechanisms of fuzzy logic inference (FLI), the calculation process has a low efficiency of the resulting value, while all informational signs are not taken into account.

Up to now, PMS controllers or controllers implemented on robust control principles have been used in technological systems in industrial control systems. The most significant drawback of the above methods is their low speed. For example, if the process flow is controlled using 10-bit sensors and the number of words coming from two sensors is $1024 * 1024 = 1048576$ words, then to select a control action in order to transfer it to the actuators and select the optimal parameters, you must complete the order 20 million operations per unit of time.

It should be noted that with an increase in the number of controlled parameters, the system performance also decreases. To overcome the above problems, the principles of fuzzy-logical control are currently widely used, which allow real-time effective control of the process in the presence of random errors. In this case, the speed of fuzzy-logical systems does not exceed several tenths of microseconds, since in order to find the control parameter it is necessary to manipulate only the only value coming from the sensor system at a given time.

It should be noted that currently the most promising direction in solving this problem is the use of universal approximators of a wide class of multidimensional nonlinear functions - adaptive models of fuzzy inference and adaptive fuzzy neural networks [1]. The parameters of adaptive models of both types are tuned by optimizing them in the sense of a certain criterion formed from data from the training sample.

Solving this optimization problem is a difficult task for a number of reasons. Firstly, this is a large dimension of the vector of parameters of the fuzzy model. Secondly, the large dimension of the search space is closely related to the problem of multiextremality of the objective function. In addition, the nature of the function depends entirely on the data of the training sample, which change with each new simulated process or object. At present, a large arsenal of tools has been accumulated for solving optimization problems, but the search for new, more effective methods continues. Gradient optimization methods are standard and well studied [2]. This group of methods uses the value of the gradient of the function to search for the extremum. The disadvantage of these methods is the need to calculate the gradient of the function, the dependence on the initial approximation. Optimization based on random search is widespread when the gradient of a function is replaced by a random vector. Genetic algorithms as part of the paradigm of evolutionary computing can solve many problems of classical optimization methods.

In [3], the use of genetic algorithms in optimization problems for fuzzy inference systems was considered. However, classical GAs and their varieties are not always effective in solving the multimodal optimization problem. Evolutionary computing is developed to improve the efficiency of fuzzy model learning algorithms along the path of creating new methods that use the ability to dynamically change the parameters of optimization algorithms and various options for parallelizing fuzzy information processing processes. Artificial immune systems (AIS) satisfy these requirements, which are characterized by such properties as recognition, diversity, learning, memory, distributed detection, self-regulation, metadynamics, network organization,

and more [4].

In [5], the application of AIS in fuzzy classification systems was considered, in particular, for generating a base of fuzzy rules. Also considered is the tuning of adaptive models of fuzzy inference implemented in the form of a fuzzy inference system and a fuzzy neural network based on AIS. To evaluate the effectiveness of the proposed immune algorithms, their work is tested on test examples. The experiments performed show that the proposed immune algorithms are capable of adapting fuzzy models for identifying nonlinear objects.

On the other hand, the implementation of traditional fuzzy-logical algorithms used in various intelligent automated control systems has a number of disadvantages, which include a reduction in the output time of the resulting value.

Solution methods.

The above is due to the fact that, firstly, there are empty solutions, the number of which increases with the increase in the number of fuzzy rules that form the basis of knowledge bases. Empty solutions appear in the conclusions of fuzzy-logical conclusions during the enumeration of terms of input variables depending on specific control rules, while they do not participate in further mathematical calculations, but significantly reduce the speed of the fuzzy-logical control system.

Secondly, the presence of zero sections in terms describing the input and output fuzzy variables that appear during the software implementation of FLI algorithms. That is, when it is necessary to perform the operation of taking the maximum and / or minimum between two terms, the program sequentially iterates over the abscissa through a certain step all possible values of the fuzzy variable specified on the universal set, and not just those values of the universal set where the value of the membership function (values along the ordinate) is nonzero.

Thus, one of the urgent tasks is to eliminate the appearance of empty solutions and zero sections.

Based on the above, this fuzzy-logic inference algorithm consists of the following steps:

1. Creation of membership function (MF) for input and output variables
2. Compilation of fuzzy control rules (FCR) describing the relationship between input and output parameters
3. The calculation of the values of the degree of truth for each FLI
4. Creating a knowledge base that describes the relationship between input and output variables of the system
5. Entering information from sensors
6. Determination of cutoff coefficients for conclusions
7. Calculation of cut-off levels to determine the FLI mechanism
8. Determination of the truncated membership functions of the conclusions of the FLI mechanism
9. The union of truncated MF
10. Defuzzification

Output parameter output. In view of the above, a structural diagram of an automated control system for actuators is proposed (Fig. 1), which includes an adaptation block that is presented to correct not only parameters, but also the structure of control stages.

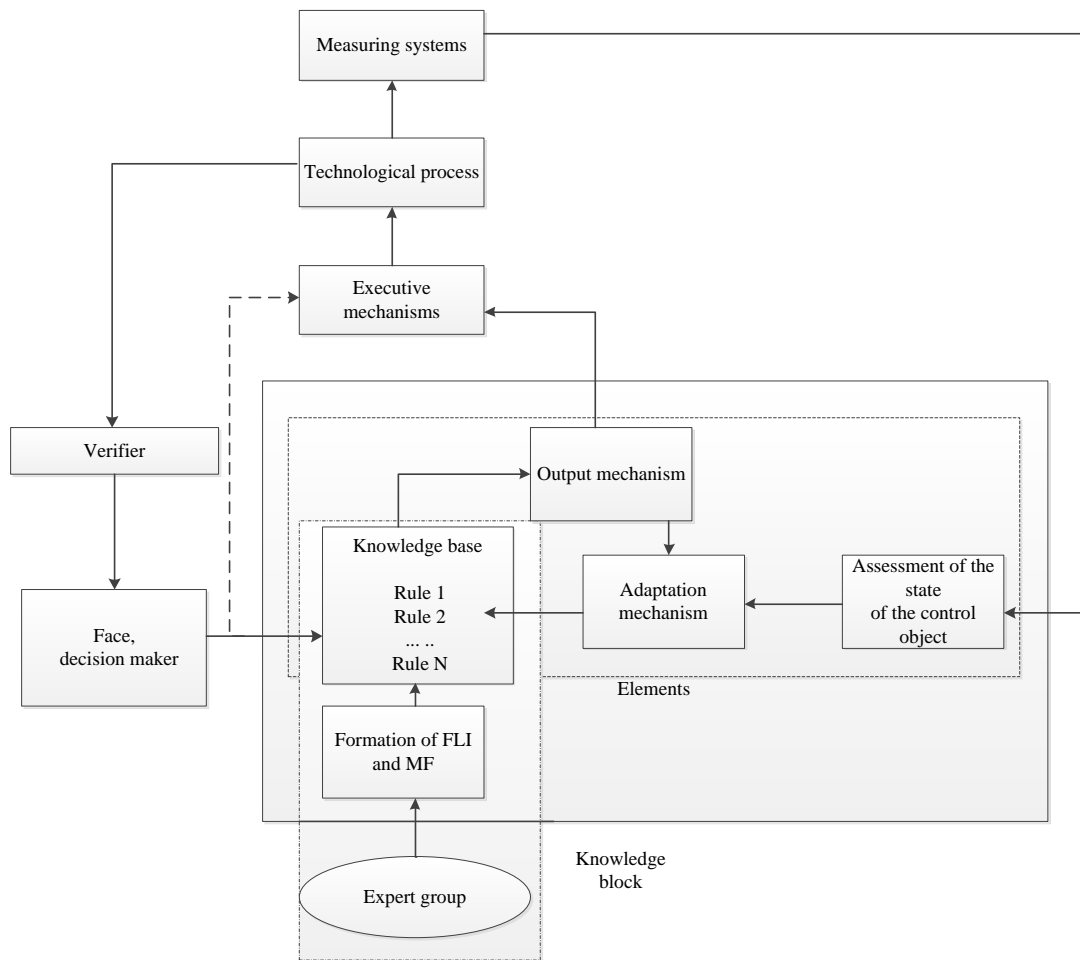

Fig. 1. Block diagram of an automatic control system for actuators

In the “adaptation block”, not only the parameters are corrected, but also the structure of the control stages, that is, the entire control system as a whole. The adaptation block consists of the following blocks "Output mechanism"; "Assessment of the condition of the OS"; "Knowledge base"; "The mechanism of adaptation."

The disadvantage of the scheme is the large error of the learning results of the neuro-fuzzy network, which is 8%. This means that if the output of the control system should be a result of 100, then an 8 percent error will form a result equal to 92 (Takagi-Sugeno model).

Solution Results

In order to reduce the learning outcomes, the following neuro-fuzzy network was developed based on the proposed high-speed algorithm of fuzzy logical inference.

Its advantage is that the 4th layer has fewer conclusions, which increases the efficiency of decision-making. At the same time, in the fourth layer there is a reduction in operations in an adaptive neuro-fuzzy inference system, operating on the basis of the mechanism of a high-speed algorithm of fuzzy-logical inference (M), by 2 times compared to traditional ANFIS.

This network works as follows.

In the control process, information from the sensors enters the output unit and the state assessment unit. Then, from the output unit and the state evaluation unit, the obtained values of the control parameter are sent to the “adaptation” block, in which, in turn, the reference value of the control parameter is set. The adaptation unit calculates the control parameter in real time and

compares the calculated and reference values. And if they do not match, it adapts the results to reference values, after which it generates control signals. A neuro-fuzzy network based on a high-speed algorithm of fuzzy-logical inference is presented in Figure 2.

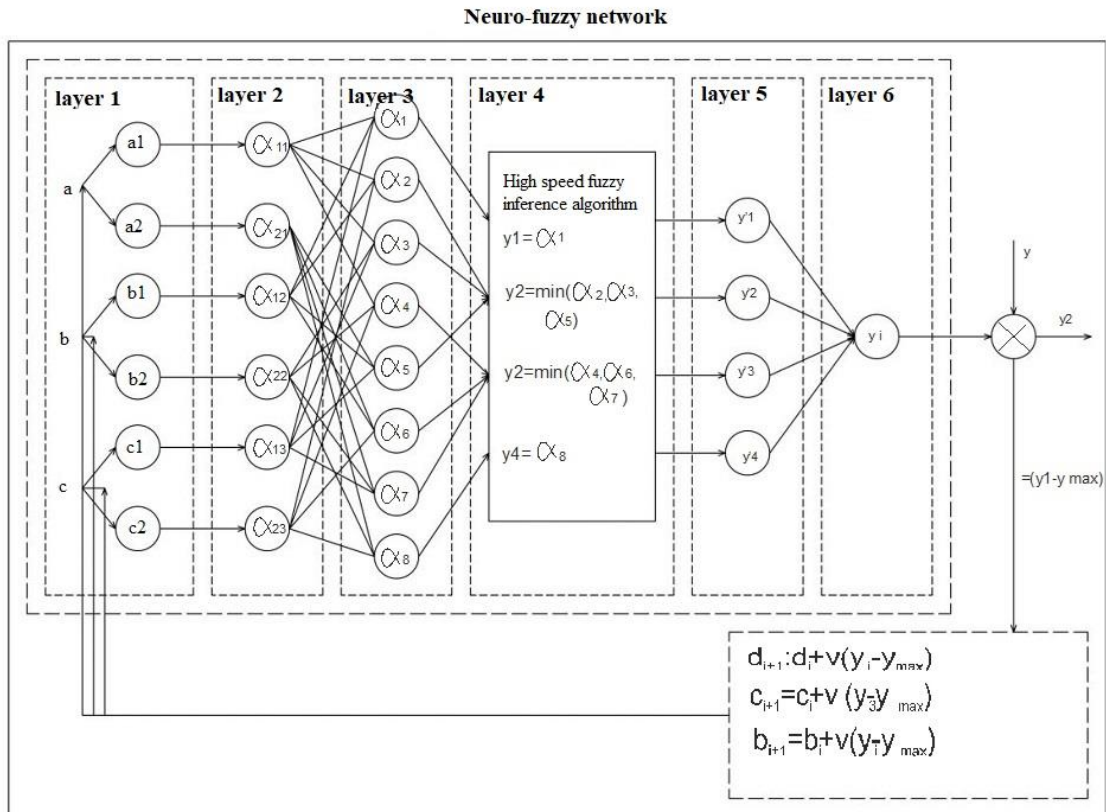

Fig. 2. The scheme of a neuro-fuzzy network based on a high-speed algorithm of fuzzy-logical inference

Let the following data be received from the active control system of the equipment of the facility: $a = 15$, $b = 26$. The degrees of membership for each premise will be:

$$\alpha_{11}=1; \alpha_{12}=0,04; \alpha_{13}=0,76;$$

$$\alpha_{21}=1; \alpha_{22}=0,15; \alpha_{23}=0,94.$$

The cut-off levels for each premise of the FLI are found:

$$\alpha_1=\min(1, 0,04, 0,76)=0,04;$$

$$\alpha_2=\min(1, 0,04, 0,94)=0,04;$$

$$\alpha_3=\min(1, 0,15, 0,76)=0,15;$$

$$\alpha_4=\min(1, 0,15, 0,94)=0,15;$$

$$\alpha_5=\min(1, 0,04, 0,76)=0,04;$$

$$\alpha_6=\min(1, 0,04, 0,94)=0,04;$$

$$\alpha_7=\min(1, 0,15, 0,76)=0,15;$$

$$\alpha_8=\min(1, 0,15, 0,94)=0,15.$$

The clipping levels are calculated:

$$y'_1=0,04;$$

$$y'_2=\min(0,04, 0,15, 0,04)=0,04;$$

$$y'_3=\min(0,15, 0,04, 0,15)=0,04;$$

$$y'_4=0,15.$$

Next, truncated (MF) are found and, based on the center of gravity method, control decisions are determined:

$$y'' = 32,25;$$

$$p' = 86,98 + 0,13v - 15,6s.$$

Let the set value be, the output value $y_{3ad} = 38$ of the neuro-fuzzy network is calculated: $y_1'' = 39,83$. It can be seen that after the first iteration of training, the error between the two values is already $39,83 - 38 = 1,83$.

The resulting value is $y_{10}'' = 36,98$.

Findings

The results showed that after 10 iterations, the accuracy of training is about 5%, therefore, it is necessary to carry out the correction of one parameter. In this case, it is advisable to change the fuzzy-logical operations in the third or fourth layer of the neuro-fuzzy network - instead of min, use the max operation $y_{3ad} = 38$, then 15 iterations will be required to get the given result, which is one more than in the considered example.

Thus, the proposed structural-parametric adaptation in the problems of controlling technological equipment allows one to reduce the number of iterations in the process of learning the fuzzy logic inference algorithm, speed up the learning process of the system due to the high-speed fuzzy logic inference algorithm, and reduce the error in the results of learning a neuro-fuzzy network from 8 to 1 %.

Reference

1. Bobir M.V. Modifitsirovannii algoritm nechetko-logicheskogo vivoda v zadachax upravleniya oborudovaniem s CHPU // Mexatronika , Avtomatizatsiya, Upravlenie. 2001. №4. S.26-32.
2. Bobir M.V., Titov V.S., Ansiferov A.V. Algoritm visokoskorostnoy obrabotki detaley na osnove nechetkoy logiki // Mexatronika, Avtomatizatsiya, Upravlenie, 2012. №6. S.21-26.
3. Otsenka dostovernosti pri modelirovanii nechetko-logicheskix sistem / Bobir M.V., Titov V.S., P.V. Globin, N.A. Milostnaya // Promishlennye ASU i kontrolleri, 2012. №7. S. 32-38.
4. Bobir M.V. Metodi postroeniya funktsiy prinadlejnostey dlya nechetkix baz znaniy // Promishlennye ASU i kotrolleri, 2011. №2. S.27-33.
5. Bobir M.V., Titov V.S., CHervyakov L.M. Adaptatsiya slojnix sistem upravleniya s uchetom prognozirovaniya vozmojnix sostoyaniy // Avtomatizatsiya i sovremennye texnologii, 2012. №5. S.3-10.
6. Pupkov K.A., Barkin A.I., Voronov E.M. i dr.; Pod red. N.D. Egupova. Metodi klassicheskoy i sovremennoy teorii avtomaticheskogo upravleniya: Uchebnik dlya vuzov. V 3 t. -Moskva: Izd-vo MGTU im. N.E. Bauman, 2000.
7. Rutkovskaya D., Pilinskiy M., Rutkovskiy L. Neyronnie seti, geneticheskie algoritmi i nechetkie sistemi- M.: Goryachaya liniya-Telekom, 2006.- 452 s.
8. Pegat A. Nechetkoe modelirovanie i upravlenie.- M.: IUIT; BINOM, Laboratoriya znaniy, 2012. -798 s.
9. Antipin A.F. Sravnitelniy analiz bistrodeystviya diskretno-logicheskogo regulyatora // Programmnye produkti i sistemi. 2010. № 1 (89). S. 75–77.
10. Yurkevich V.D. Sintez nelineynix nestatsionarnix sistem upravleniya s raznotempovimi protsessami. SPb.: Nauka, 2000. 287 c.
11. Siddikov I., Iskandarov Z. Synthesis of adaptive-fuzzy control system of dynamic in conditions of uncertainty of information // International Journal of Advanced Research in Science, Engineering and Technology. Vol. 5. Issue 1. January 2018. pp. 5089-5093.

12. Zadeh, L.. Fuzzy Sets. Inf Cont, Vol. 8, Pp. 338–353, 1965.
13. Cox, E. , The Fuzzy Systems Handbook. Ap Professional - New York.1994.
14. Mehrotra, K., Mohan, C. K., And Ranka, S. ,Elements Of Artificial Neural Networks. The Mit Press, 1997
15. Lin, C-T., and C. S. George Lee. «Neural-network-based fuzzy logic control and decision system» Computers, IEEE Transactions on 40.12 (1991): 1320-1336.
16. Takagi, H. & Hayashi, I., Nn-Driven Fuzzy Reasoning. International Journal Of Approximate Reasoning, Vol. 5,Issue 3, 1991.
17. Rotach, V.Ya. (2008) The Theory of Automatic Control. Moscow: Publishing House Moscow Power Engineering Institute, - 396 p.
18. Pelusi, D., Mascella R. (2013) Optimal control algorithms for second order systems, Journal of Computer Science, vol. 9, no. 2, pp. 183–197.
19. Astrom, K.J. (2006) Advanced PID control/ K. J. Astrom, T. Hagglund – ISA (The instrumentation, Systems, and Automation Society), 2006 – 460 p.
20. Wang, L. And Mendel, J., Back-Propagation Fuzzy System As Nonlinear Dynamic System Identifiers. Proceedings Of Ieee International Conferenceon Fuzzy Systems, Pages 1409–1416, 1992.